



QUALITY... PLAIN & SIMPLE®

Automatic Electronic Sport Mode Shifter Installation Instructions

General Installation Notes:

Please read these instructions completely before beginning the installation. If you have any questions, please call.

Before beginning the installation, disconnect the negative battery cable and use wheel chocks to block the vehicle's wheels.

Make sure the engine, transmission, body and frame are properly grounded.

All Lokar Installation Instructions can be found by visiting www.lokar.com/instructions.html.

Shifter is shipped in a locked condition. DO NOT ATTEMPT TO REMOVE THE LOCKING BOLTS OR MOVE THE SHIFTER LEVER UNTIL STEP 4!

Refer to Fig. 1 for the component names.

Tools and Materials Required:

- Standard Allen wrenches: 5/64", 1/8", 5/32", 3/16", 10mm, 15mm
- Wrench or Socket Sizes: 3/8", 7/16", 1/2", 9/16", 7/8", 15/16", 10mm, 15mm
- Tape Measure
- Metal cutting tool, such as a hacksaw or a die grinder with a cut-off wheel
- Drill and 5/16" drill bit
- Ohmmeter
- Wire cutters/strippers
- Wire crimping or soldering tools

The Lokar Electronic Sport Mode Shifter has two basic configurations, **Position 1** and **Position 2**. As it is shipped from the factory, all **four speed** applications are set up for Position 1 and will allow four gear selector positions: Park, Reverse, Neutral, and Drive. Manual Mode is activated by depressing the release button and moving the shifter lever to the passenger side from the Drive position.

All **six speed** applications are shipped from the factory set up for Position 2, and will allow five gear selector positions: Park, Reverse, Neutral, Drive, and Sport Mode. Manual Mode is activated by depressing the release button and moving the shifter lever to the passenger side from the Sport Mode position.

Some GM six speed applications require Manual Mode to be accessed from the Drive gear selector position (Position 1).

If your GM six speed controller requires Manual Mode to be accessed from the Drive gear selector position, the Shifter must be converted to Position 1 BEFORE you install the Shifter. See "Converting from Position 2 to Position 1" on Page 5.

For any other applications that need the opposite position from what was received, call Lokar Technical Support at 877-469-7440.

© 2024 Lokar, Inc.

Automatic Electronic Sport Mode Shifter Installation Instructions

Building American Quality... With A Lifetime Warranty!®

TOLL FREE 1-877-469-7440 • tech@lokar.com • www.lokar.com

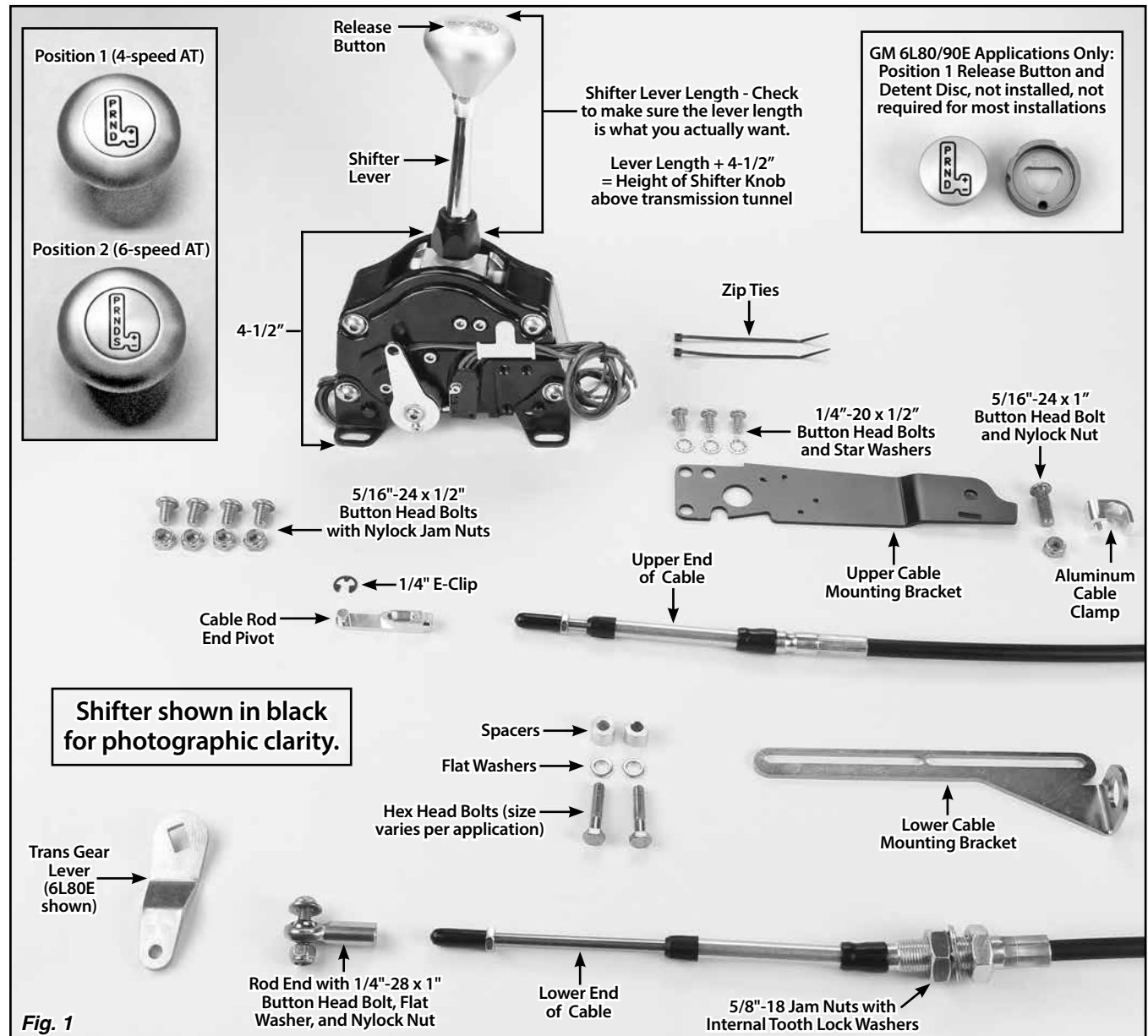

Fig. 1

Lokar Shifters are designed to operate specific transmissions. Before installing the Shifter, verify you have the proper model for your transmission. If your Shifter does not seem to connect to the transmission properly, do not make modifications during installation as this may void your warranty. Call for assistance.

Ford AODE and 4R70W Only:

These two transmissions require the installation of a Lokar Selector Shaft and Trans Arm Kit (included). The Selector Shaft and Trans Arm Kit can be installed with the transmission in the vehicle on most applications. However, it is easier to install the Selector Shaft and Trans Arm Kit while the transmission is removed. These installation instructions assume you have completed the installation of the new Selector Shaft and Trans Arm Kit. NOTE: The "trans arm" on the AODE and 4R70W is equivalent to the "trans gear lever" in these instructions.

All Applications:

The Lokar Electronic Sport Mode Shifter is designed for and intended to be used with an aftermarket Transmission Control Unit (TCU). You will need to follow the instructions for your particular TCU in order to connect the shifter wiring. The Lokar Electronic Sport Mode Shifter may also be used with a factory Powertrain Control Module (PCM), but there are too many different combinations and too many variables for these instructions to cover those possibilities. If you are going to use the Lokar Electronic Sport Mode Shifter with a factory PCM, you will likely need aftermarket tuning software to create a custom program for the PCM, and you will need to create a custom wiring harness to connect the Shifter to your PCM.

Installation and Operation:

Step 1: If your vehicle already has a shifter of any type installed, disconnect all shifter linkage and remove the shifter and its related hardware. If your transmission has an MLPS (Manual Lever Position Sensor) on the selector shaft, do not remove it.

Step 2: Install the upper cable mounting bracket onto the Lokar Shifter using a 5/32" Allen wrench and three 1/4"-20 x 1/2" button head bolts with internal tooth lock washers. **Fig. 2**

Step 3: Determine exactly where you want the Shifter to be located. The Shifter may be mounted either on top of the transmission tunnel or floor, or inside a console or dashboard. It MUST be mounted inside the passenger compartment and away from the weather.

Step 4: Place the Shifter in the desired location. Temporarily remove the two #10-32 x 1/2" socket head bolts used to lock the Shifter from moving. **Fig. 2**

WARNING: DO NOT MOVE THE QUAD ARM ON THE SHIFTER WHILE THESE BOLTS ARE REMOVED, OR THE INTERNAL GEARS COULD BECOME OUT OF SYNC!

Operating the Sport Mode Shifter

The Shifter is designed to lock in Park and in Neutral. You must depress the release button in the top of the shifter knob in order to shift out of Park or Neutral.

With gear plate in Position 1:

Depress the release button and hold it down while moving the shifter lever, and the Shifter will stop in Drive. To engage Manual Mode, depress the release button and push the shifter lever to the passenger side from Drive. The shifter lever can then be "bumped" forward or backward to shift up or down. Push the lever to the driver side to exit Manual Mode.

With gear plate in Position 2:

Depress the release button and hold it down while moving the shifter lever, and the shifter lever will stop in Sport Mode. To engage Manual Mode, depress the release button and push the shifter lever to the passenger side from Sport Mode. The shifter lever can then be "bumped" forward or backward to shift up or down. Push the lever to the driver side to exit Manual Mode. To engage regular Drive mode, push the lever forward one notch from Sport Mode (this detent is provided by the transmission, and is not a separate detent in the Shifter). **NOTE:** The lever can only be moved to Manual Mode from the Sport Mode position, not from Drive.

Step 4 continued: Move the shifter lever forward into Park and rearward into the lowest gear position, making sure the shifter lever will not interfere with the dash when in Park, or with the seat when in Drive or Sport Mode.

NOTE: If after installation you find the shape or length of the shifter lever is not suitable for your application, Lokar has a number of different styles and lengths of Shifter Lever Conversion Kits available for purchase separately through our dealer network.

Step 5: Move the shifter lever back into Drive (Position 1 Shifters) or Sport Mode (Position 2 Shifters). Reinstall the #10-32 x 1/2" socket head bolts you removed in **Step 4** and lightly snug them down, but do not fully tighten.

WARNING: FAILURE TO REINSTALL THESE BOLTS COULD ALLOW THE INTERNAL GEARS TO BECOME OUT OF SYNC!

Step 6: There will need to be an opening in the floor for the shifter cable to pass through. Determine where the best spot would be, keeping in mind the straighter the cable is, the more smoothly the Shifter will operate. The shifter cable should be protected by a grommet (not included) where it passes through the transmission tunnel or floor. Cut any necessary openings now.

Step 7: Use a 3/16" Allen wrench to loosen the button head bolts that attach the shifter mounting brackets to the Shifter, just enough so the brackets can slide if needed. Place the Shifter assembly in position on the vehicle. Make sure the shifter mounting brackets are sitting flush on the surface they will be bolted to. Mark the center of the bolt holes in the shifter mounting brackets. Center punch the marks, and drill 5/16" diameter holes.

Step 8: Attach the shifter mounting brackets to the vehicle using four 5/16"-24 x 1/2" button head bolts and nylock jam nuts. Once the Shifter assembly is mounted, use a 3/16" Allen wrench to tighten the bolts that attach the shifter mounting brackets to the Shifter.

Step 9: Make sure the transmission is in Park by rotating the original trans gear lever clockwise as far as it will go.

All EXCEPT Ford AODE & 4R70W: Remove the original trans gear lever from the transmission selector shaft. Install the new trans gear lever onto the selector shaft, pointed down and towards the front. Re-use the original nut to secure the trans gear lever.

Step 10: Install the lower cable mounting bracket on the driver side of the transmission pan, with the cable mounting hole towards the rear of the transmission, using the provided hex head bolts, flat washers, and spacers.

On GM six speed transmissions, the cable mounting hole is on the top side of the bracket. On all others it is on the bottom side of the bracket. **NOTE:** If the transmission has an aluminum pan, the spacers may not be necessary.

Step 11: Remove one of the 5/8"-18 jam nuts and internal tooth lock washers from the lower end of the cable. Install the cable into the lower cable mounting bracket. Then, reinstall the lock washer and jam nut onto the cable.

Step 12: Feed the other end of the cable up through the opening in the transmission tunnel or floor. When routing the cable, make sure it is not touching the exhaust or any moving parts. The cable should be routed as smoothly as possible without any sharp bends.

Step 13: Make sure the 1/4"-28 jam nuts are installed on each end of the cable. Then, install the rod end onto the cable at the transmission end and the rod end pivot at the Shifter end, threading them both on approximately halfway. Do not tighten the jam nuts against the rod end or rod end pivot yet.

Step 14: **The inner cable needs to be fully extended all the way out at the transmission end when it is attached to the trans gear lever.** Pull the inner cable out as far as it will go. Determine if the rod end needs to be attached to the inside or the outside of the trans gear lever in order for the cable to be as straight as possible.

Adjust the position of the lower cable mounting bracket, the position of the cable itself in the bracket, and/or the rod end so the hole in the rod end lines up with the hole in the trans gear lever with the inner cable fully extended and the transmission in Park. Attach the rod end to the trans gear lever using a 1/4"-28 x 1" button head bolt, flat washer, and nylock nut. **Figs. 3, 4, 5, 6, and 7.** The button head bolt can be installed from either direction, but make sure the rod end is sandwiched between the trans gear lever and the flat washer. **Fig. 8**

NOTE: 4L60E transmissions ONLY: Install the 1/8" spacer (provided) between the rod end and the trans gear lever. Fig. 9

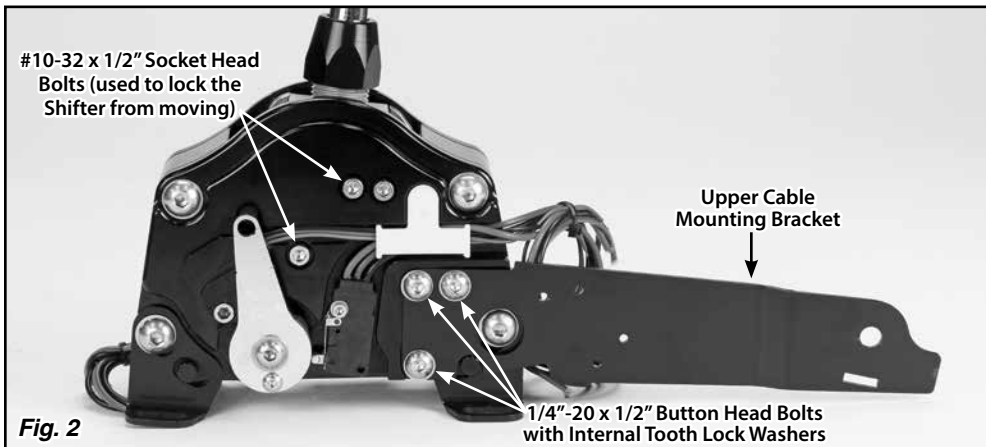

Fig. 2

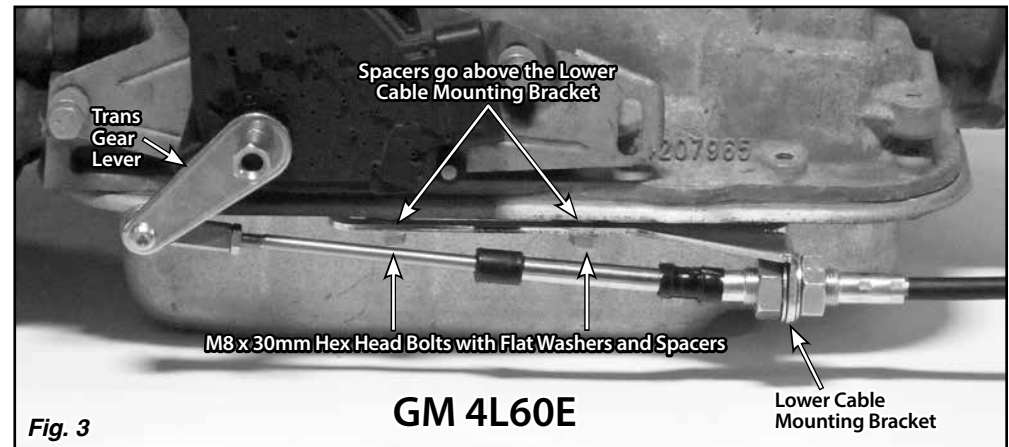
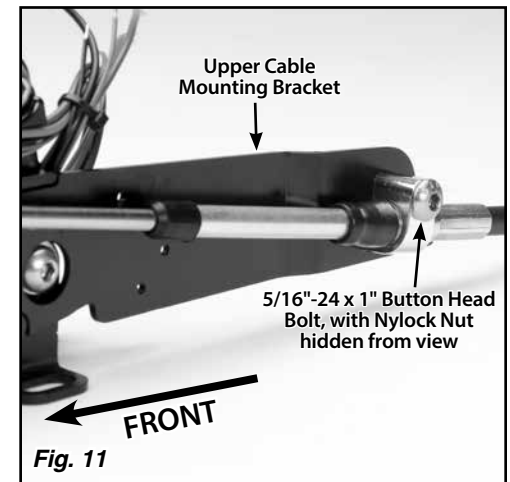
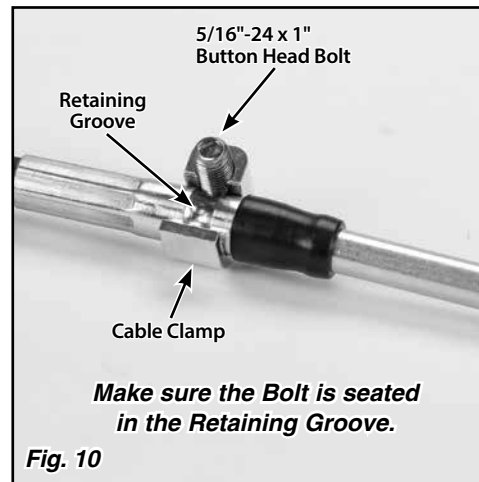
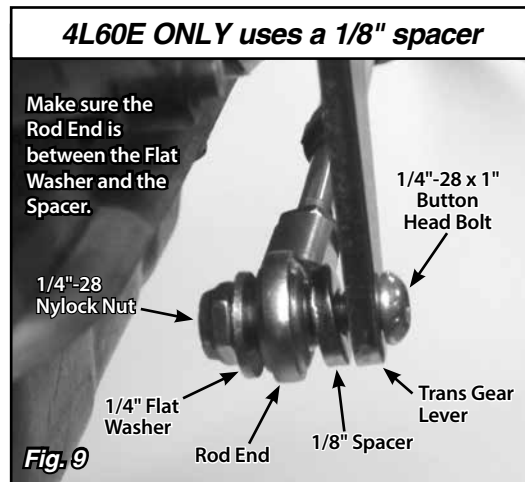
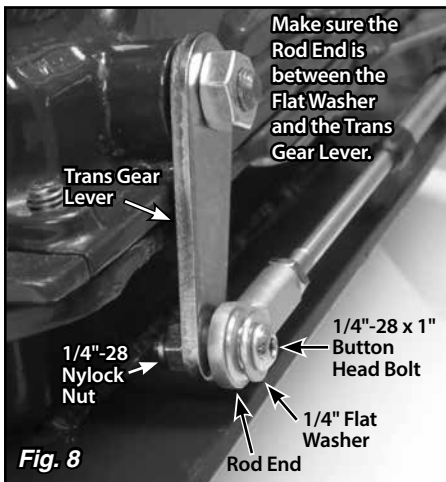
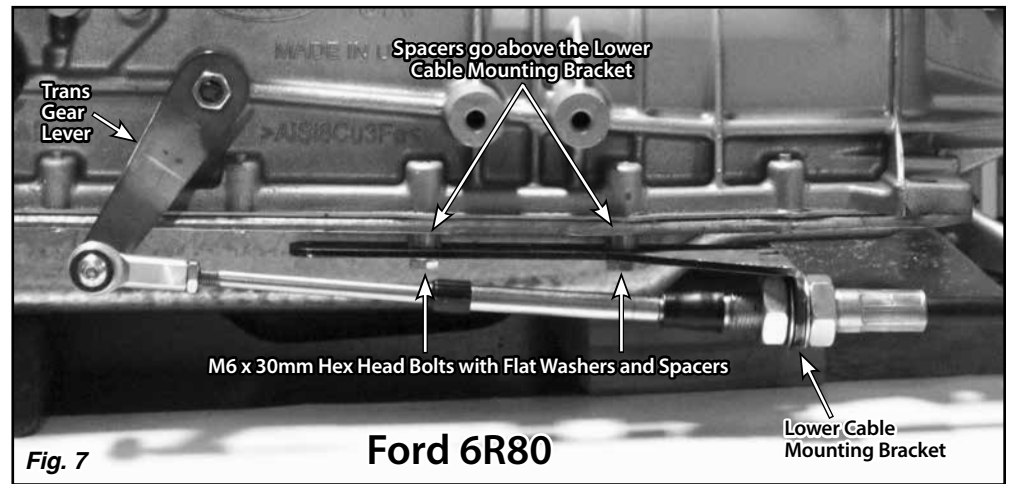
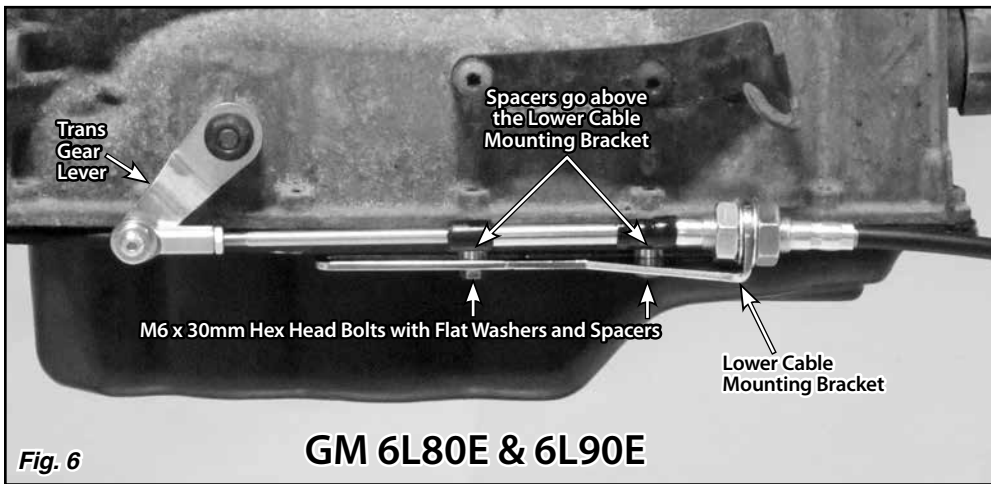
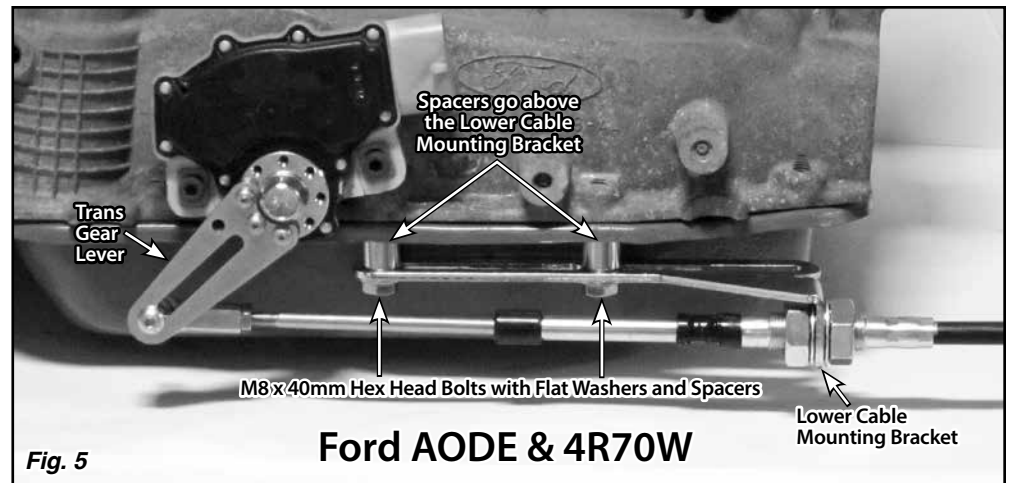
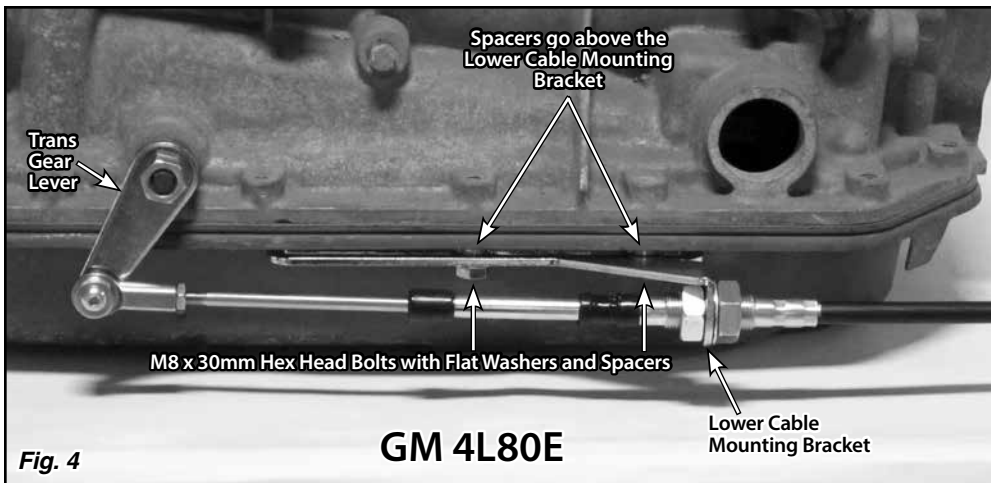

Fig. 3



Step 15: Insert the 5/16"-24 x 1" button head bolt into the upper cable clamp, and position the upper cable clamp on the cable, making sure the bolt is seated in the retaining groove. **Fig. 10**

Install the upper cable clamp onto the upper cable mounting bracket so the bottom end of the clamp fits into the slot in the bracket and the 5/16"-24 x 1" button head bolt fits into the bolt hole in the bracket. Secure with a nylock nut. **Fig. 11**

Step 16: Use a 5/32" Allen wrench to remove the two #10-32 x 1/2" socket head bolts called out in **Fig. 2**. Then, depress the release button and move the shifter lever all the way forward into Park.

WARNING: DO NOT MOVE THE SHIFTER LEVER REARWARD, OR THE INTERNAL GEARS MAY BECOME OUT OF SYNC!!!

Step 17: Adjust the position of the rod end pivot on the end of the cable so the stud on the rod end pivot lines up with the hole in the quad arm on the Shifter. Push the stud through the hole and install the 3/16" E-clip into the groove on the stud. **Fig. 12**

Step 18: Make sure the release button still moves up and down freely. The release button should be flush with the knob in Park and Neutral. In the Reverse position, you cannot pull the lever back into Neutral without depressing the release button.

While the shifter lever is in Park, make sure the transmission is firmly in the Park detent, with no tension on the cable. You can verify there is no tension on the cable by removing the 1/4"-28 x 1" button head bolt with nylock nut that attaches the rod end to the trans gear lever. Make sure the quad arm and trans gear lever do not move during the adjustment procedure. Also, make sure the inner cable is still fully extended at the transmission end.

Adjust the rod end or rod end pivot in or out as needed until the bolt will pass freely in and out of the rod end and the trans gear lever. Reinstall the 1/4"-28 nylock nut and the flat washer onto the bolt and tighten.

Once you have the shifter cable adjusted correctly, tighten the 1/4"-28 jam nuts on the ends of the cable, and the 5/8"-18 jam nuts at the lower cable mounting bracket.

Final Gear Stop Removal (optional, if desired)

The Lokar Electronic Sport Mode Shifter is restricted at the factory so the position you select Manual Mode from is the lowest transmission detent you can reach with the Shifter. Some transmission controllers offer features that allow for extra functionality when the trans gear lever is in lower gear positions. By removing the final gear stop from the Lokar Shifter, you can gain access to this functionality if desired. You will also be able to provide physical, manual gear selection if that option is available with your transmission and controller.

To eliminate the final gear stop, remove the Final Gear Stop bolt shown in **Fig. 12** on the driver side of the Shifter, using a 5/32" Allen wrench.

NOTE: The Shifter cannot be moved over into the Manual Mode from any of the lower gear selector positions. The shifter lever must be in Drive (Position 1) or Sport Mode (Position 2) in order to be moved over into Manual Mode.

Wiring the Manual Mode and Bump-Shift Switches

The Lokar Electronic Sport Mode Shifter can function just like a traditional automatic transmission shifter if you wish. It is not necessary to even connect the wiring for the Manual Mode switches if you do not want to use those features.

There are four switches on the Sport Mode Shifter: Manual Mode, upshift, downshift, and neutral safety. The Manual Mode, upshift and downshift switches are single pole double throw (SPDT) momentary switches. However, the Manual Mode on-off switch is being used as a "latching" (instead of momentary) switch in this application.

The Manual Mode switch is on the driver side of the Shifter as shown in **Fig. 12**. The black wire is connected to the normally closed (NC) terminal. The blue wire is connected to the normally open (NO) terminal. The brown wire is connected to the common (COM) terminal. **Fig. 13** Manual Mode is activated by pushing the shifter lever to the passenger side when the shifter lever is in either Drive (Position 1) or Sport Mode (Position 2). The Manual Mode switch will then provide continuity between the brown wire and the blue wire. Pushing the lever back to the driver side turns Manual Mode off.

The upshift, downshift, and neutral safety switches are identical to each other. Each switch has black, blue, and red wires. The red wire is connected to the normally closed (NC) terminal. The blue wire is connected to the normally open (NO) terminal. The black wire is connected to the common (COM) terminal. **Fig. 13**

The downshift switch is inside the front of the Shifter, and it is activated by pulling the shift lever rearward and releasing it when in Manual Mode. At rest, the switch provides continuity between the black wire and the red wire. Activating the downshift switch provides momentary continuity between the black wire and the blue wire, signaling the transmission controller to command a downshift.

The upshift switch is inside the rear of the Shifter, and it is activated by pushing the shifter lever forward and releasing it when in Manual Mode. At rest, the switch provides continuity between the black wire and the red wire. Activating the upshift switch provides momentary continuity between the black wire and the blue wire, signaling the transmission controller to command an upshift.

Please note with a fully electronic transmission, the Shifter only sends a request to the transmission controller to execute a shift. The response to a shift request may not be immediate, or in some situations may not happen at all, depending on the vehicle speed, engine load or RPM, and how the controller is programmed.

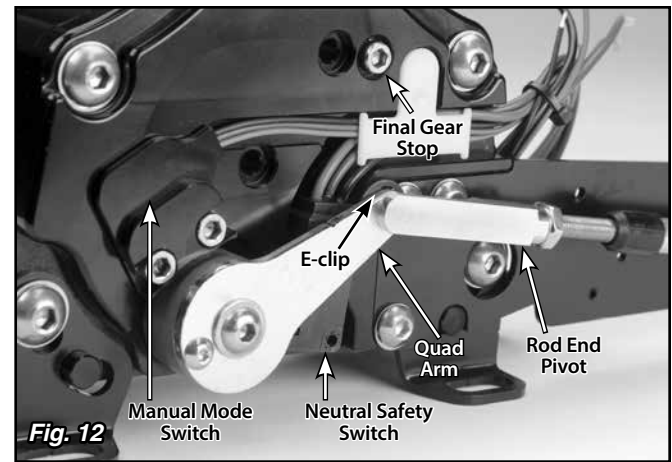

Fig. 12

Neutral Safety Switch Wiring

If your transmission controller has a neutral safety switch output, you may use that output instead of the neutral safety switch on the Shifter.

Step 19: For the neutral safety switch to function properly, the shifter linkage must be adjusted correctly.

The neutral safety switch is identical to the upshift and downshift switches, except in any gear selector position other than Park or Neutral, the switch is held in its normally open (NO) position, with no continuity between the black and red wires. The red and black wires will have continuity when the Shifter is in the Park or Neutral position.

Test for continuity by connecting ohmmeter leads to the red and black wires on the neutral safety switch. When the shifter linkage is adjusted correctly, you will only have continuity between the red wire and the black wire when the shifter lever is in Park or Neutral. Continuity in any other gear requires readjustment of the shifter linkage. **NOTE:** The blue wire on the neutral safety switch will not be used.

Step 20: Connect the neutral safety switch between your ignition switch and starter circuits. Check the wiring of your fuse panel:

- **If there are (2) connections for a neutral safety switch**, route a #12 (or heavier) stranded wire from these terminals in your fuse panel to the red and black wires on the neutral safety switch. That completes the Neutral Safety Switch wiring.

- **If your fuse panel does not have neutral safety switch connections**, locate the wire going from the ignition switch to the starter. If GM color codes are used, this wire will usually be purple. After locating the wire, disconnect it from the starter. This wire must be connected to the red wire on the neutral safety switch. The black wire coming from the neutral safety switch must then be connected to the same stud on the starter where the original wire was removed. When connecting the black wire to the starter, be sure to use wire at least the same size or larger than the original.

Step 21: Reconnect the negative battery cable and check operation. Make sure the engine will not start in Reverse or any forward gear. **If it does, follow the shifter linkage adjustment procedure again. If your vehicle should ever start in any gear other than Park or Neutral, please readjust the shifter linkage.** Tighten all brackets and bolts securely and there should be no movement or misadjustment. If you have any questions after following this procedure, please call Lokar Technical Support.

Use the two provided zip ties to secure the switch wiring behind the Shifter to the upper cable mounting bracket, passing the zip ties through the small holes on the bracket as shown in **Fig. 14**.

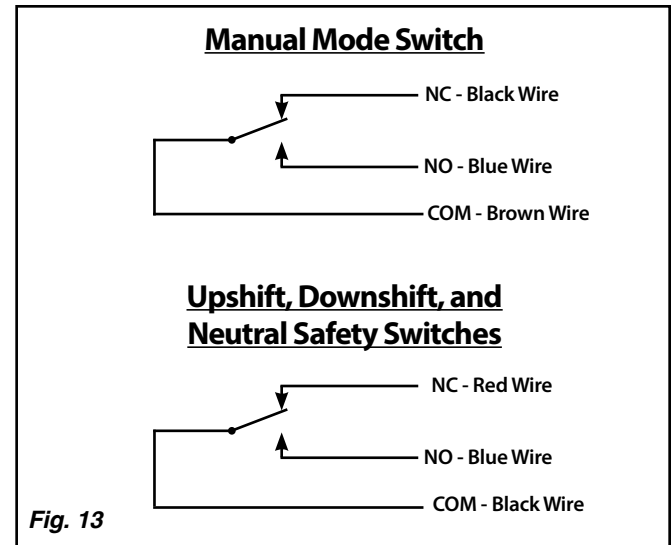

Fig. 13

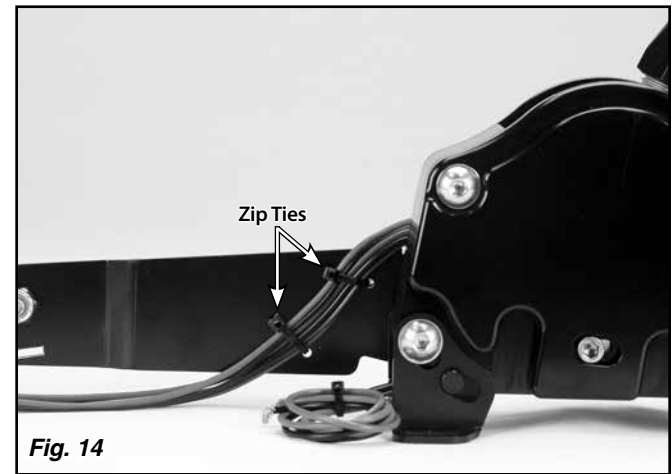

Fig. 14

Lokar Shifter Knob Removal Instructions

To Remove the Shifter Knob:

- Step 1:** Make sure the shifter lever is all the way forward in the Park position.
- Step 2:** Loosen the jam nut below the shifter knob. **DO NOT** loosen or remove the set screw in the knob. **Fig. 15**
- Step 3:** Turn the shifter knob counter-clockwise to remove.

To Install the Shifter Knob:

- Step 1:** Make sure the jam nut is still in place on the shifter lever.
- Step 2:** Thread the shifter knob onto the shifter lever until the release button comes up flush with the top of the shifter knob.
- Step 3:** Tighten the jam nut up against the bottom of the shifter knob.
- Step 4:** Check to make sure depressing the release button allows the shifter lever to be moved, and the shifter lever still locks in Park and Neutral. If the shifter lever will not come out of Park with the release button fully depressed, tighten the knob one turn and check it again. If the shifter lever does not lock in Park, loosen the knob one turn and check it again.

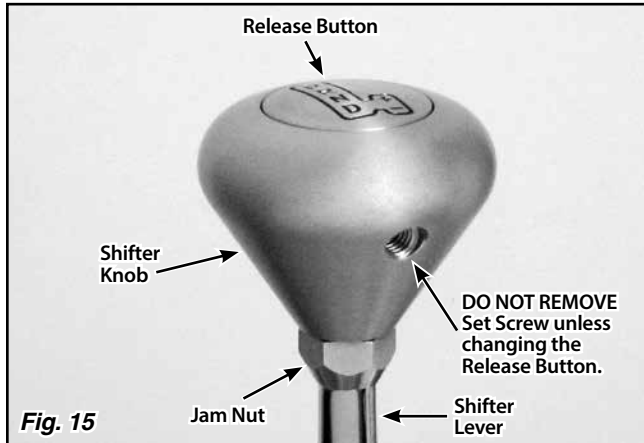

Fig. 15

Converting from Position 2 to Position 1

If you have a GM six speed automatic transmission and your transmission controller requires Manual Mode to be accessed with the shifter lever in the highest forward gear selector position, follow these steps to convert the Shifter to Position 1. The Shifter must be removed from the vehicle to perform this conversion.

The Shifter in Fig. 17 through Fig. 20 has been disassembled ONLY FOR PHOTOGRAPHIC CLARITY. DO NOT disassemble the Shifter for this procedure!

- Step 1:** Verify the shifter lever is in Sport Mode. Depress the release button, and move the lever to the passenger side into Manual Mode.

Lay the Shifter on its side with the driver's side down and the shifter lever pointing away from you. Note the 1/4"-28 x 1/2" socket head bolt shown in **Fig. 16** is at the left side of the slot it is in.

- Step 2:** Reach inside the Shifter and support the gear plate. Use a 3/16" Allen wrench to remove the 1/4"-28 x 1/2" socket head bolt. **Fig. 16**

- Step 3:** While holding the gear plate in position, flip the Shifter over so it is laying on the passenger side.

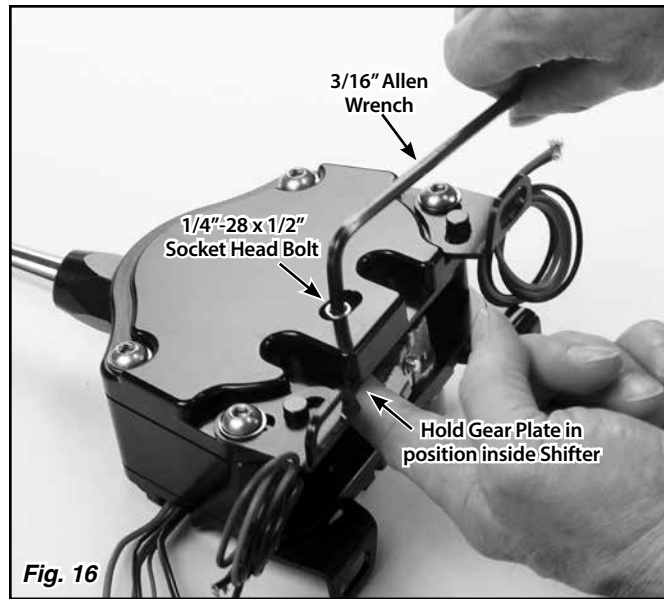

Fig. 16

- Step 4:** Note the relationship of the notches in the top of the gear plate to the alignment studs protruding from the side plate in **Fig. 17**. There is a "1" and a "2" on either side of the gear plate bolt hole. In **Fig. 17**, the "2" is closest to an alignment stud, showing the gear plate is in Position 2.

Lift the gear plate slightly so it clears the recess in the side plate, and move the gear plate slightly towards you so it clears the alignment studs. **Fig. 18** Move the gear plate to the left (**Fig. 19**) and then forward into its new position so the studs are in the other pair of notches. Now, the "1" on the gear plate is closest to an alignment stud (Position 1). **Fig. 20**

- Step 5:** Apply blue thread locking compound to the 1/4"-28 x 1/2" socket head bolt that threads into the gear plate. Hold the gear plate in place and flip the Shifter back over onto its driver side.

- Step 6:** Install the bolt into the gear plate and tighten using a 3/16" Allen wrench. The bolt will now be at the right side of the slot when looking at the passenger side of the Shifter.

Move the shifter lever back to the center position, out of Manual Mode, but **keep the lever in the Sport Mode position.**

- Step 7:** Note you can currently see the text on the outside of the quad arm. Use a 3/32" Allen wrench to remove the #8-32 x 3/8" button head bolt from the quad arm. **Fig. 21**

Reach inside the bottom of the Shifter with your fingers and support the quad arm shaft. Use a 5/32" Allen wrench to remove the 1/4"-20 x 1/2" button head flange bolt from the center of the quad arm, and remove the quad arm. **Fig. 22**

- Step 8:** Remove the Position 2 detent disc (labeled GM2 on the inside). **Fig. 23** Replace it with the provided Position 1 detent disc (labeled GM1 on the inside). You will have to depress the roller on the neutral safety switch to get the detent disc in place. **Fig. 24** Also, make sure the detent plunger is seated. If the detent plunger is protruding, the detent disc can get caught on it and not seat fully. **Fig. 23**

NOTE: Do not discard the Position 2 detent disc in case you need to change back at a later date.

- Step 9:** Reinstall the quad arm flipped over so the text on the quad arm is on the side towards the Shifter. Apply blue thread locking compound to the threads on both of the button head bolts that attach the quad arm to the Shifter, and install the bolts. **Fig. 25**

- Step 10:** Loosen the shifter knob jam nut and unthread the knob from the shifter lever.

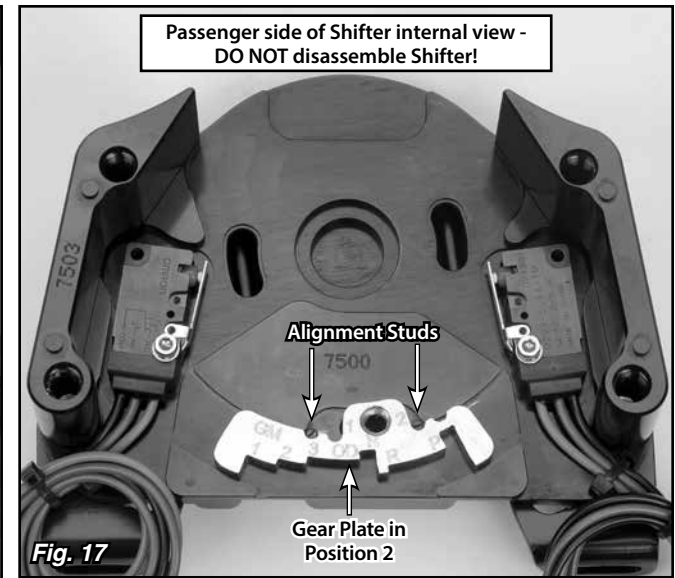

Fig. 17

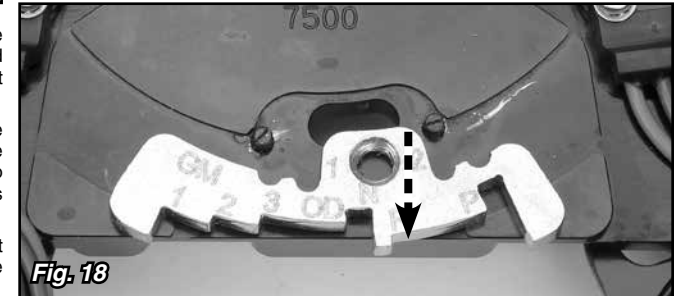

Fig. 18

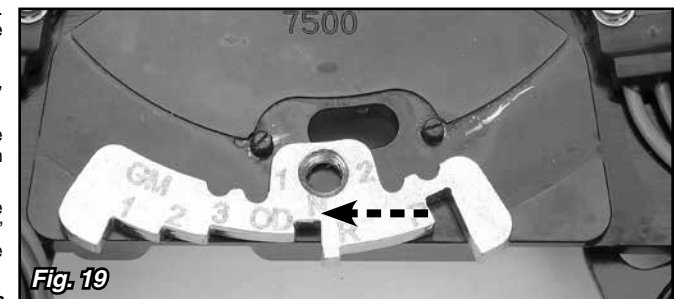

Fig. 19

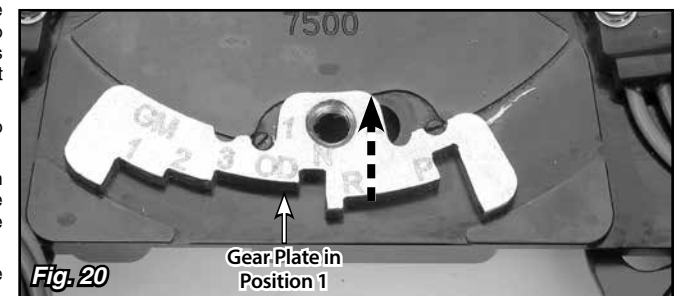

Fig. 20

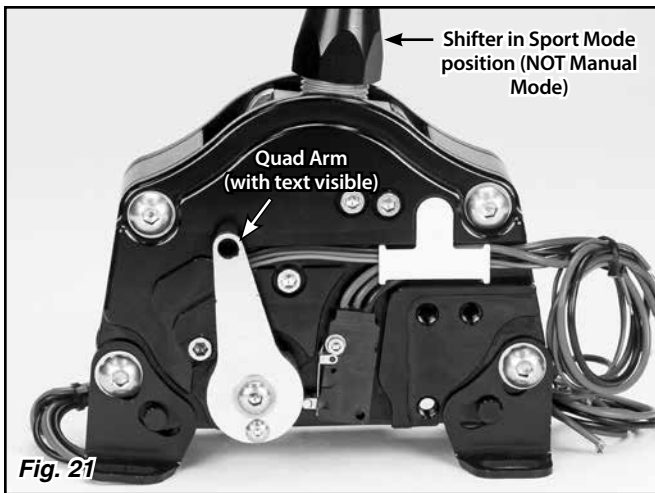

Fig. 21

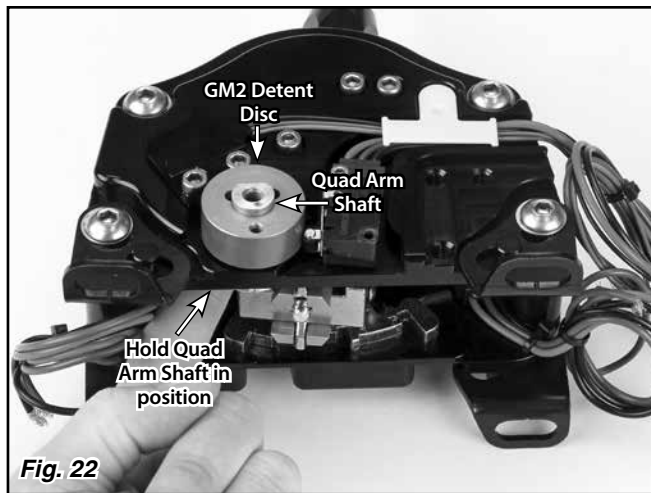

Fig. 22

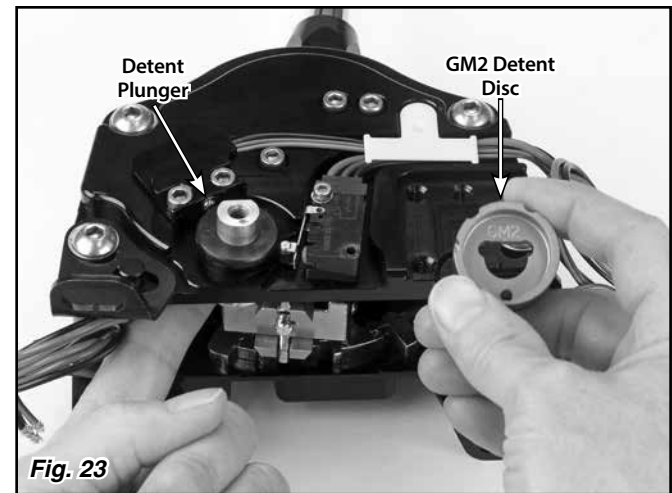

Fig. 23

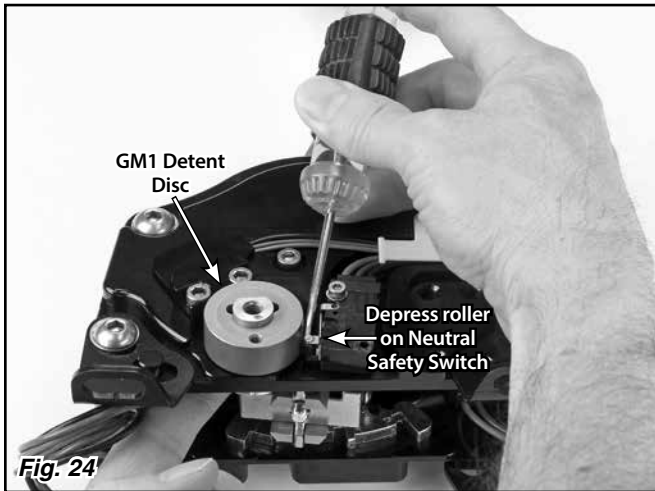

Fig. 24

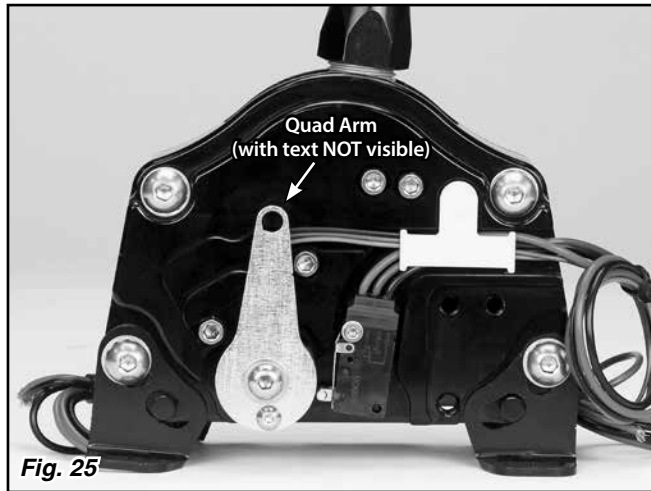

Fig. 25

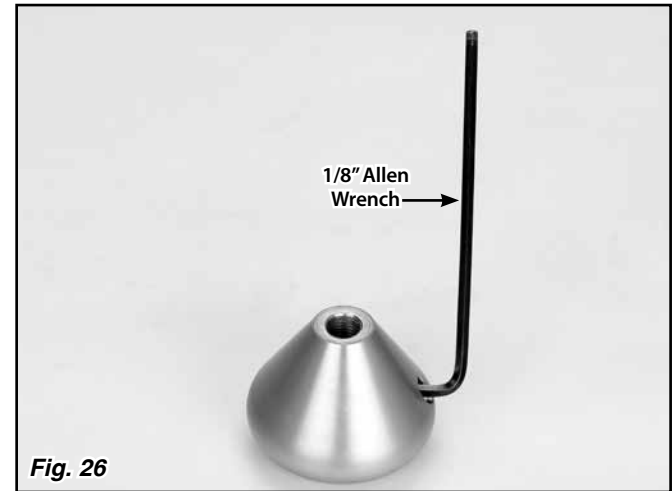

Fig. 26

Step 11: Turn the knob upside down. Use a 1/8" Allen wrench to loosen the set screw in the shifter knob just enough for the release button to slide out of the shifter knob. The release button will usually not just fall out. You will likely need to push the release button out with a screwdriver or the end of the Allen wrench. **Fig. 26**

Step 12: Remove the split Teflon™ ring from the release button. Use a pair of needle nose pliers to remove the rubber isolator from inside the release button. **Fig. 27** Install the rubber isolator into the new Position 1 release button, making sure the closed end of the rubber isolator goes into the button first.

Step 13: Place the split Teflon ring in the groove on the new Position 1 release button. Hold the ends of the split Teflon ring together under one of your fingers, and install the Position 1 release button into the knob, making sure the alignment groove in the release button is aligned with the set screw. **Fig. 28**

Step 14: Use a 1/8" Allen wrench to tighten the set screw until it lightly bottoms out against the release button. Then, loosen the set screw just enough so the release button moves freely up and down.

Step 15: Reinstall the shifter knob onto the shifter lever, following the steps in the previous section of these instructions on Page 5.

Step 16: If the Shifter had previously been installed, recheck the function of the Shifter and the neutral safety switch once the Shifter is reinstalled.

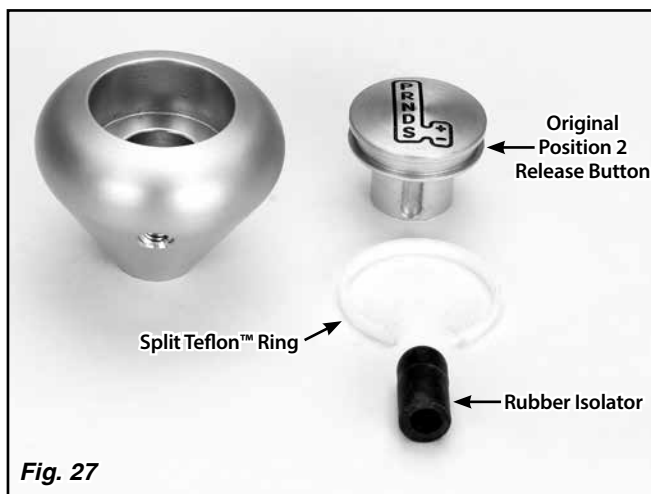

Fig. 27

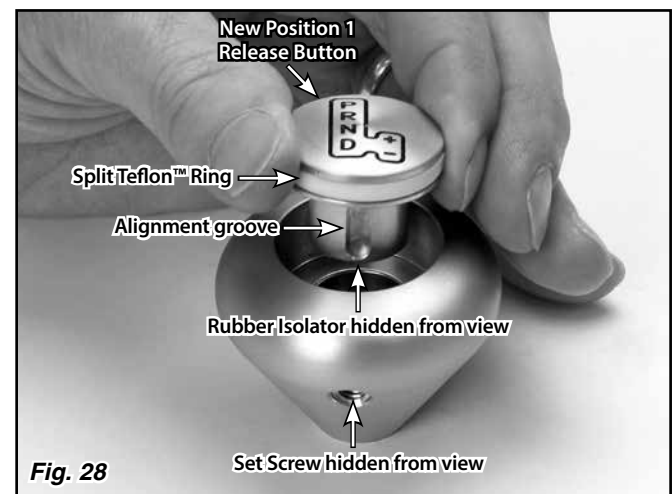

Fig. 28



3574 E. State Road 236 Anderson, IN 46017 (Ph) 765-378-4908 info@speartech.com

Lokar Tap Shifter Wiring Instructions:

The front switch is for the tap **Down** function.

The rear switch is for the tap **Up** function.

You will ignore the RED wiring on the Lokar shifter. You will also ignore the “arming” switch located at the top of the shifter. That switch does not get used.

Start-off by removing and cutting off our small toggle switch.

You will connect the front and rear switch black wires together and solder them to our yellow wire on our tap shift switch box.

Front Switch (DOWN): Black Wire – to our Yellow wire

Dark Blue – to our Red Wire

Rear Switch (UP): Black Wire – to our Yellow wire

Dark Blue – to our Green wire

****Computer reprogramming is required for proper Tap Shift functionality.****



6L80 / 6L90 Tap Shift Instructions

(applicable to floor mount shifter kit, and tap shift switch box)

Two wires coming from shifter/tap switch module:

Pink/Black - Switched Ignition/Power - Goes to any appropriate switched (key on: power, key off: no power) power source.

White/Black - Tap Up/Tap Down function. Goes to 6L80 / 6L90 transmission connector; position 7. Remove the seal (if there is one) in position 7 of your transmission connector (large, round connector). Insert this wire into the slot.

Note: If your harness has a 'tap shift' wire, you can splice the white/black wire to your harness manufacturer's supplied 'tap shift' wire.

ECM and T43 TCM reprogramming is required for tap up/tap down function.

*The Tap Shifter and Tap Shift Switch Box are **NOT** compatible with LSA E67 setups!*

Push the seal from position 7 of the transmission side, out through the other side.



Insert our white/black wire into position 7 of the harness side of the connector.

