



POWERTRAIN CONTROL SOLUTIONS
Engineering the future of driveline control.

PCS SFT-5000 USER GUIDE v3.0



PCS SFT-5000 User Guide

SFT-5000 Introduction & Theory of Operation

The PCS SFT-5000 is a floor shifter with Tap up Tap Down for GM 6L transmissions. It is a 5 position shifter, Park, Reverse, Neutral, Drive and Sport Mode. The button for Tap control is on the top of the shifter, making it easy to use in both left and right hand drive vehicles. The Tap Up Tap Down is configured for the hardwire input in Pin 7 of the transmission. The SFT-5000 also has the transmission brake interlock feature. The brake interlock prevents the driver from moving the shifter out of park unless the brake is depressed. There is a button to release the shifter from park manually in-case the vehicle loses power. The shifter assembly comes complete with the cable and mounting brackets for GM 6L/8L transmissions. Customers that are not using a Speartech harness require the Speartech pigtail add-on.
 8L90 transmission wiring goes to Speartech CANbus module

Section 1: Shifter Installation The SFT-5000 requires 12V Switched Power, Ground, 12V from the Brake Switch and a Tap shift wire to connector. *Reference Figure 1.*

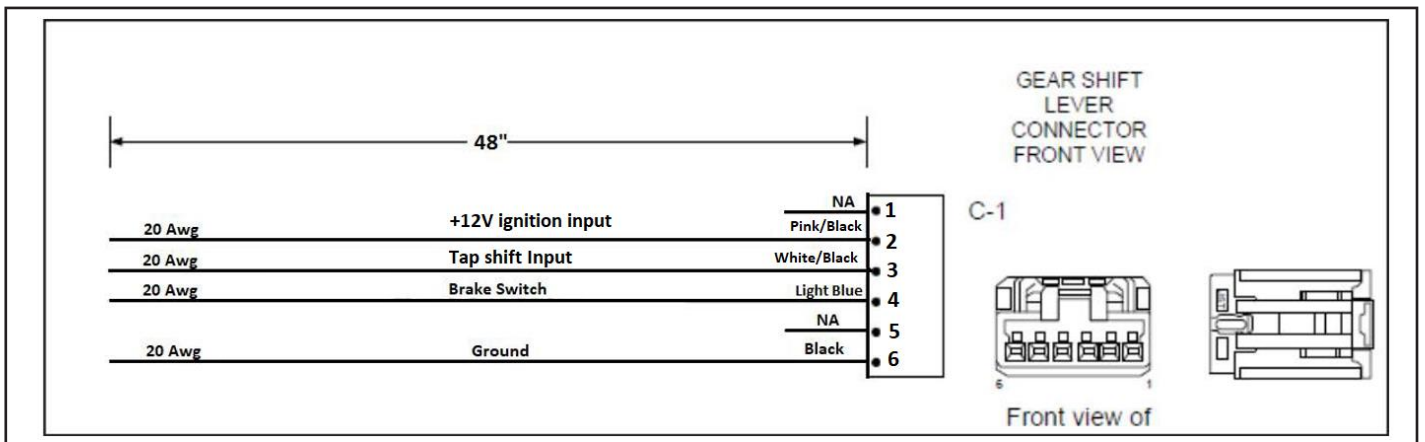

Figure 1: SFT-5000 Shifter Wiring Schematic

Shift Power Connection:

The SFT-5000 is operated on 12 volts switched power.

Wire Color	Function
Pink/Black	12V Switched Power
Black	Ground

Park Switch Connection:

The Park Switch wire should be spliced into the brake switch. It should have no voltage until the brake is depressed. The solenoid will release the interlock when it receives 12V.

Wire Color	Function
Light Blue	Brake Switch 12V

Tap Shift Wiring:

Wire Color	Function
White/Black	Tap Shift (Pin 3 on Shifter and Pin 7 on GM 6L Transmission Connector)

Section 2: Shifter Knob Installation

1. The shifter knob is held in place with a self retaining clip. To install, push down on the knob until it locks into place.
2. Prior to securing the shifter boot, locate and plug in the shifter connector. **Reference Figure 1.**



Figure 1: SFT-5000 Shifter Connector

Section 3: SFT-5000 Bracket and Shift Lever Installation Instructions

1. Install shift arm onto shifter shaft. **Reference Figure 1.**



Figure 1: Install Shift Arm

2. Install shift arm nut and tighten. **Reference Figure 2.**



Figure 2: Install Shift Arm Nut

3. Align the two brackets in this orientation. **Reference Figure 3.**



Figure 3: Align Brackets

4. Use the provided (2) M8 bolts and nuts to assemble the two brackets together. **Reference Figure 4.**

Note: The bolt heads should be facing away from the transmission.



Figure 4: Assemble Brackets

5. Mount the bracket assembly to the transmission using the provided (2) M8 bolts. **Reference Figure 5.**

Note: All bolts should be facing the same direction.



Figure 5: Mount Bracket

6. Release the cable end adjustment by lifting up on the white clip to allow the cable end to move along the cable freely. **Reference Figure 6.**



Figure 6: Release Cable End Adjustment

7. Slide the cable mount groove into the cable bracket until the two clips click into place. **Reference Figure 7.**



Figure 7: Install Cable to Bracket

8. Snap the cable end onto the ball of the shift arm. **Reference Figure 8.**

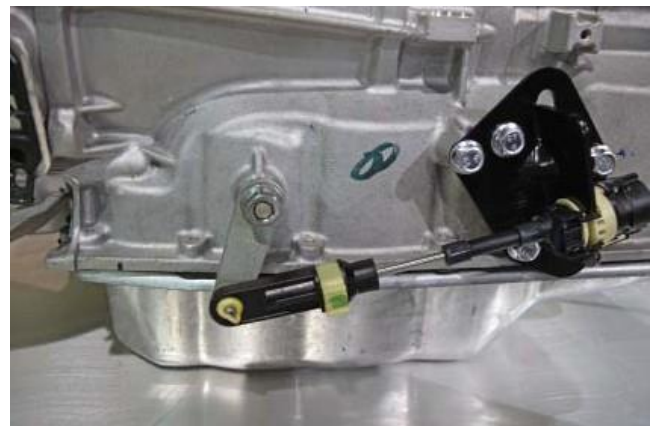

Figure 8: Install Cable End onto Shift Arm

9. While the transmission and the shifter are in park (All the way forward), snap the cable end adjustment clip back onto the cable end. This will lock the cable end to the cable in the proper position. **Reference Figure 9.**

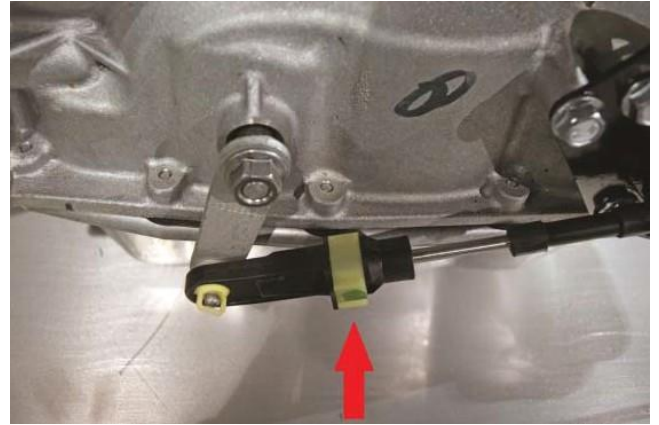
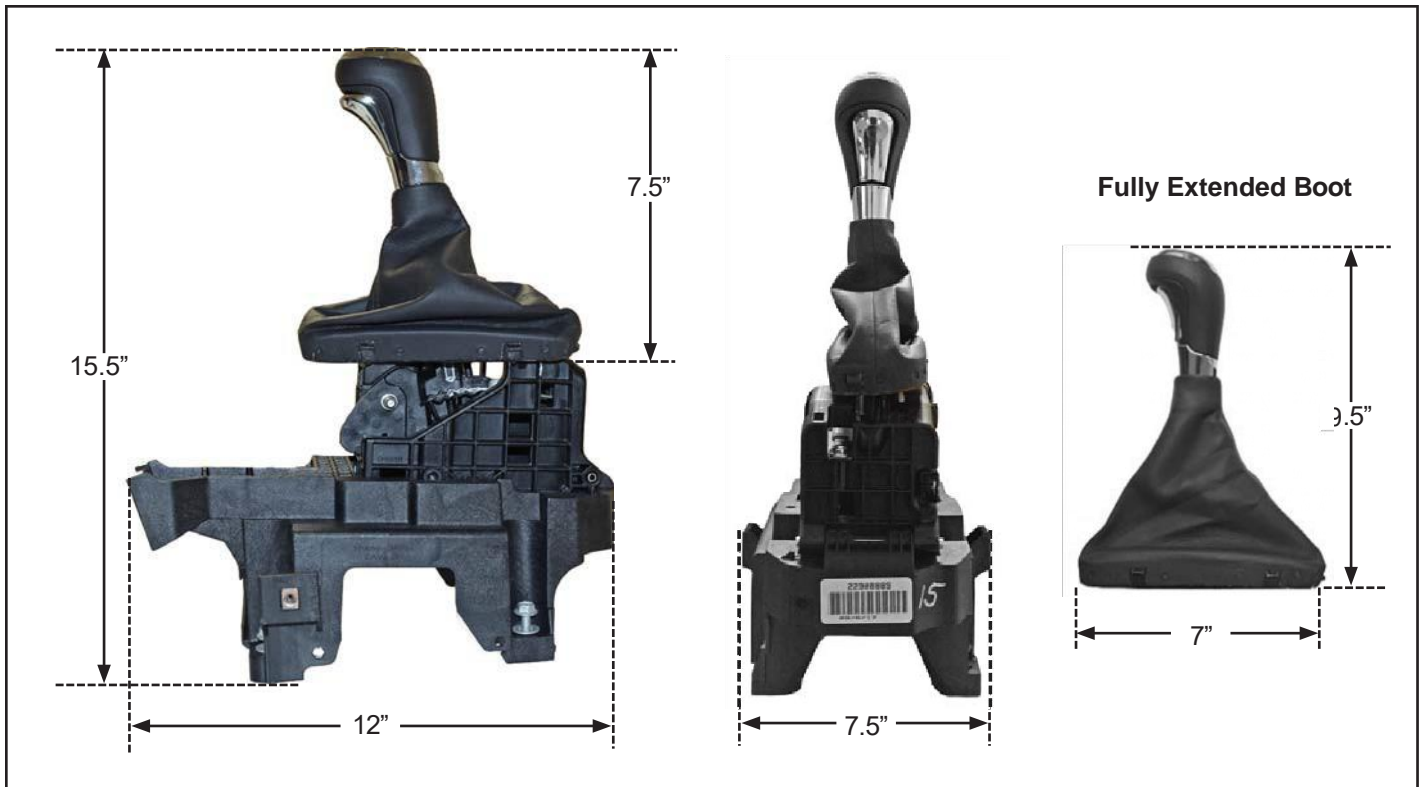

Figure 9: Snap Cable Adjustment in Place

SFT-5000 Dimensions*



*Measurements are approximate.

LIMITED WARRANTY STATEMENT. Powertrain Control Solutions, LLC. Warrants all merchandise against defects in factory workmanship and materials for a period of 12 months after purchase. This warranty applies to the first retail purchaser and covers only those products exposed to normal use or service. Provisions of this warranty shall not apply to Powertrain Control Solutions, LLC. Product used for a purpose for which it is not designed, or which has been altered in any way that would be detrimental to the performance or life of the product, or misapplication, misuse, negligence or accident. On any part or product found to be defective after examination by Powertrain Control Solutions, LLC., Powertrain Control Solutions, LLC. will only repair or replace the merchandise through the original selling dealer or on a direct basis. Powertrain Control Solutions, LLC. assumes no responsibility for diagnosis, removal and/or installation labor, loss of vehicle use, loss of time, inconvenience or any other consequential expenses. The warranties herein are in lieu of any other expressed or implied warranties, including any implied warranty of merchantability or fitness, and any other obligation on the part of Powertrain Control Solutions, LLC., or selling dealer.